

Eclipse Counter Bracket Information & Installation



8" x 8" Eclipse
Counter Bracket



Face Plate Mounted
Option

MODEL NUMBER	COUNTER DEPTH	ACTUAL-SIZE	WEIGHT CAPACITY
EC-0808	12 inches	8-5/8" x 8-5/8"	125 lbs ea.
EC-0812	18 inches	11-5/8" x 8-5/8"	100 lbs ea.
Weight capacity is based on evenly distributed static loads			

Engineered and manufactured in the United States by:
Rangine Corporation, Needham Massachusetts
Tel: 781-455-8700, 800-826-6006 Fax: 781-455-8702
www.rakks.com

Rakks Eclipse Brackets can support counters or shelves up to 18 inches deep. This attractive low-profile design is easy to install without visible hardware. TIG welded extruded aluminum construction provides sturdy support for stone and solid surface materials. Machined aluminum end caps provide a smooth and near-seamless termination. Stocked in clear and black anodized finishes, Eclipse Brackets can support loads up to 250 pounds per pair. Contact us for information on our full line of counter support brackets and shelving hardware.

Keyhole Installation

1. At the stud, or on blocking place a vertical line starting from the underside of the counter top, mark two holes, one 1" from the top and the other 5" below the first.
2. Drill a 3/16" diameter hole through the wall 2 inches deep.
3. Install the #14 x 2 inch pan head screws provided leaving the underside of the screw head about 3/16" away from the wall surface. This gap may need to be adjusted to an 1/8" for a tight fit.
4. Insert the counter bracket through the two keyholes over the screw heads and tap down the bracket all the way. Apply clear silicone on the horizontal surface of the bracket and install the counter.

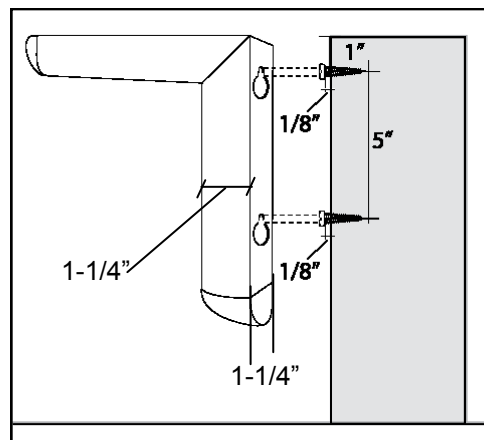

Installation Note: Check with counter manufacturer to determine maximum unsupported spans and overhang.

Cantilevered Configuration

Eclipse brackets are ideal for cantilevered counters that require additional bracing or support. The EC-0812 can support counters up to 18" deep. When used in a cantilevered configuration, Eclipse Brackets should be installed PRIOR to the installation of the counter.

Face Plate Installation

If your cantilevered counter has already been installed, you can order the Eclipse Bracket with an optional Face-plate mounting kit. This factory installed option allows you to screw the bracket to the wall using four # 8 x 2 inch color matched screws.

Shelf Configuration

The Eclipse bracket can be used as a sturdy and attractive fixed shelf support. When used as a shelf support it is important that silicone be applied to the top of the bracket to keep the shelves from tipping or otherwise falling off. Suggested spacing for Eclipse brackets is every 32". Best when installed into wooden studs or blocking.

Installation Note: Shelves should be secured with silicone adhesive to avoid tipping.

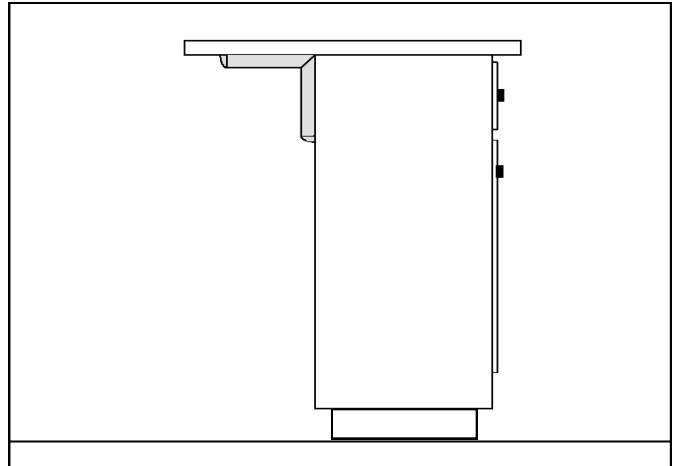

Cantilevered Configuration

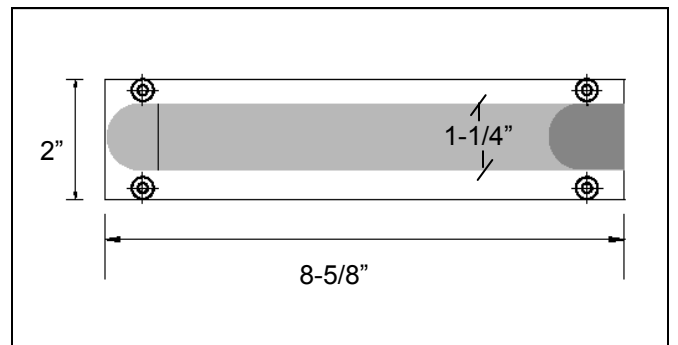

Face Plate Mounting Option

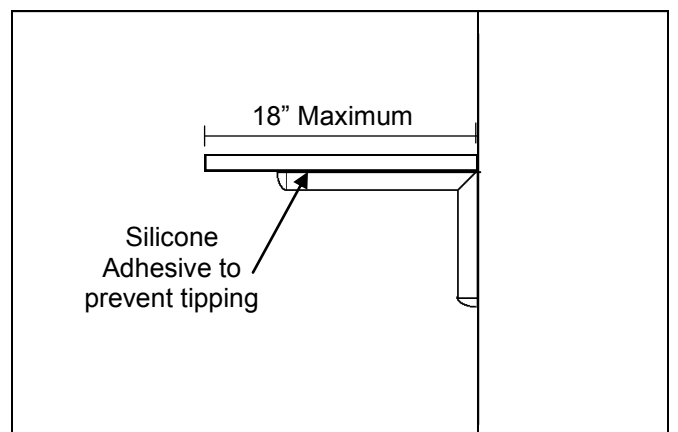

Shelf configuration

Engineered and manufactured in the United States by:
Rangine Corporation, Needham Massachusetts
Tel: 781-455-8700, 800-826-6006 Fax: 781-455-8702
www.rakks.com